

Piston Distributors, Metering Units

1-5001-US

For single-line total-loss lubrication systems



Group 320
0.01 - 0.16 ccm



Group 321
0.03 - 0.1 ccm



Group 340
0.01 - 0.16 ccm



Group 350
0.1 - 0.6 ccm



Group 390
0.2 - 1.5 ccm

Piston distributors meter out and distribute the oil delivered by an intermittently actuated pump.

The quantities of oil for the individual lube points are determined by exchangeable metering nipples. The metered amount is indicated on the individual nipples. The amount needed to cover the total oil demand can then be further regulated via the lubricating frequency.

To meet the required quantities and comply with spatial constraints it is possible to choose among four distributor groups that differ in terms of their metering ranges and sizes.

The functional principle of the groups is the same, but there are differences in design.

Different distributor groups can be used in one installation.

Please note:

Seal material: NBR.

In general, the operating conditions specified for the respective pump units will also apply to the distributors, with due attention to be given to the permissible limit values.

Limit values for the distributors:

Temperature range: 0 °C to +80 °C

Effective oil viscosity: 5 mm²/s to 2500 mm²/s.

Function

- ① The amount of oil intended for the lube point is stored in front of the piston in the distributor.
- ② When the central lubrication pump starts delivering oil, the piston moves and the oil in front of it is fed to the lube point at a main line pressure of 12-45 bars.
- ③ After the pressure is relieved (≤ 1 bar) in the main line the distributor's piston returns to its initial position and once again lets a certain quantity of oil flow into the space in front of it.

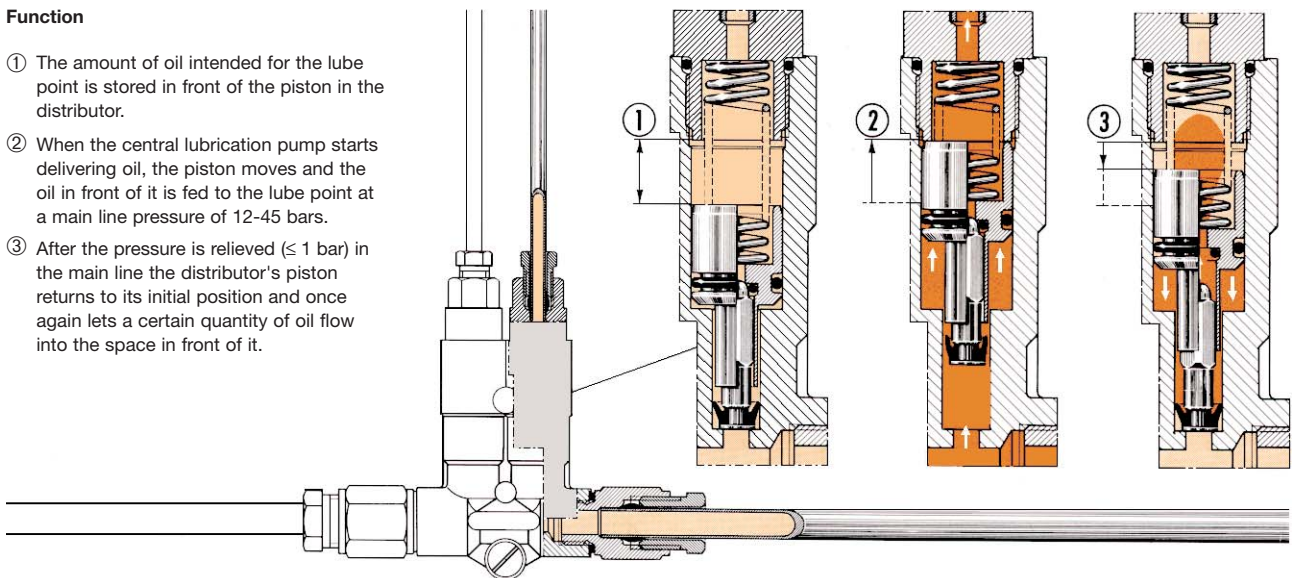

Single-line total-loss lubrication system with piston distributor for oil

Function

A pump feeds the lubricant through the main line to the piston distributors. From there it is directed to the lube points in precisely metered quantities. This takes place in a time- or pulse-controlled sequence.

Planning

1. Determine the type of drive to be used for the oil pump (manual, electric for three-phase current or AC, pneumatic).
2. Select the lubricant. Then determine the pump unit and type of distributors.

Please note: approval from WILLY VOGEL AG should be obtained when special lubricants are used.

3. Determine the number of lube points and define the amount of lubricant required to meet the needs of each point. Ascertain the total amount of lubricant needed per unit of time or clock pulse. Then dimension the contents of the lubricant reservoir.

Choice of distributors

Select the piston distributors on the basis of the metered quantity and spatial constraints.

The ratio of the metered quantities in respect to each other should be the same as the consumption of the individual lube points.

The total amount needed by the installation is then regulated by the number of lube cycles per unit of time.

Laying an installation

When installing a centralized lubrication system, lay the main lines and distributors in such a way that any air in the system can escape on its own via the lube points.

To do so, mount the distributors at appropriate places and **at the end of the installation** in such a way that the connections to the lube points **point upward** (cf. Fig. 1).

The main lines from the pump to the distributors must, if possible, be laid with a **rising gradient**.

If lines have to be routed to distributors at lower locations, proceed in accordance with Fig. 2.

Check the main-line resistance values, especially in regard to the relief routine, when specially large systems and ones with a large number of branches are involved or when highly viscous oils are used.

Each distributor port may be connected to only **one** lube point!

Do not connect the secondary line (connection: distributor – lube point) to the lube point until bubble-free oil emerges at its end after repeated actuation of the pump. It might be necessary to fill long secondary lines with oil first.

If a secondary line is blocked or broken, that will have no effect on the remaining lube points in the system.

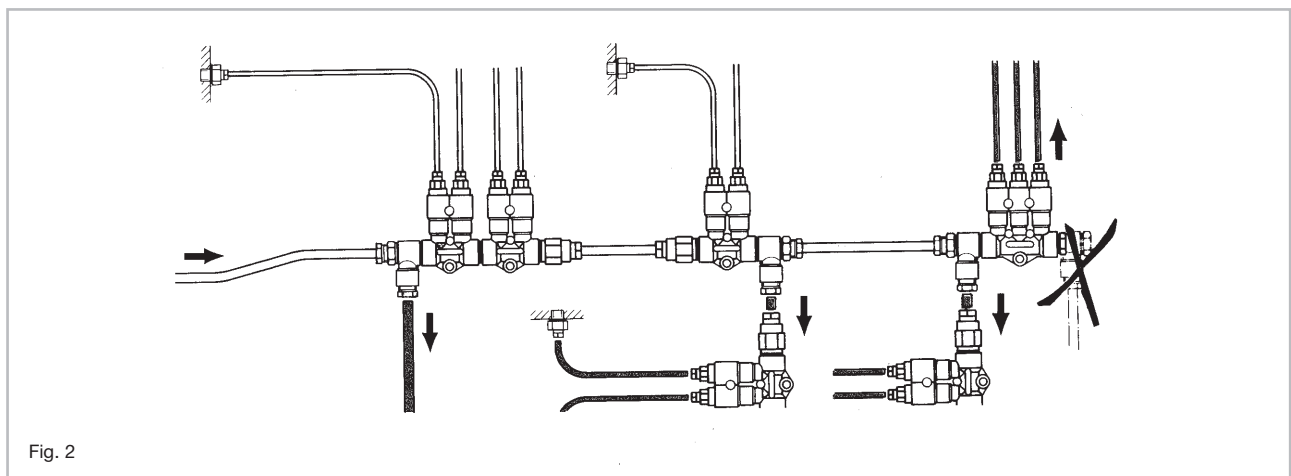
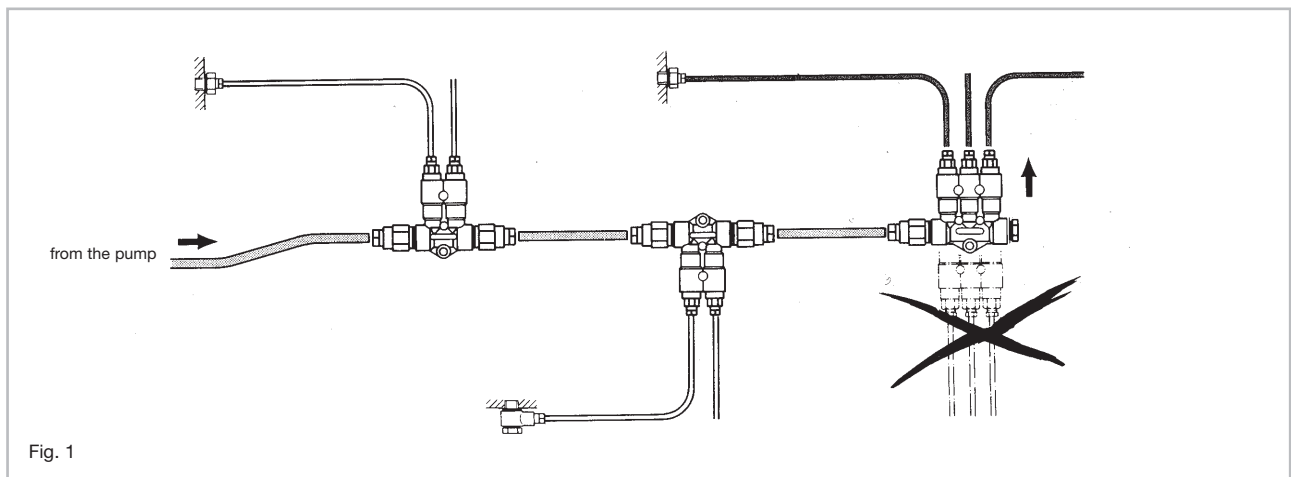

**Installation planning, basics:
lathe with compact system**

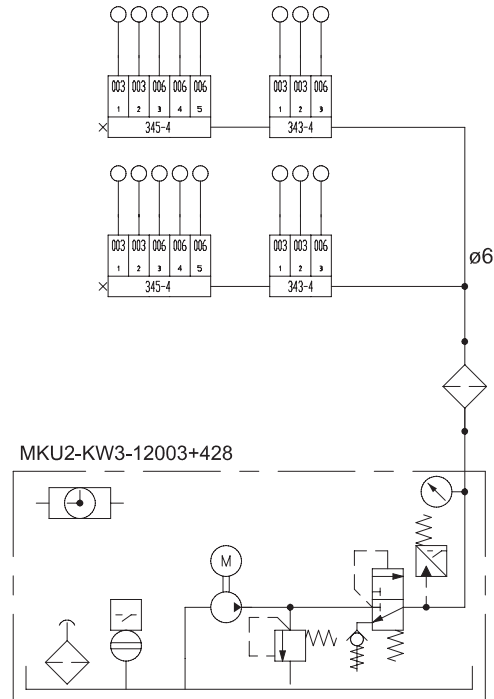

Practical example: universal milling machine with zoned system

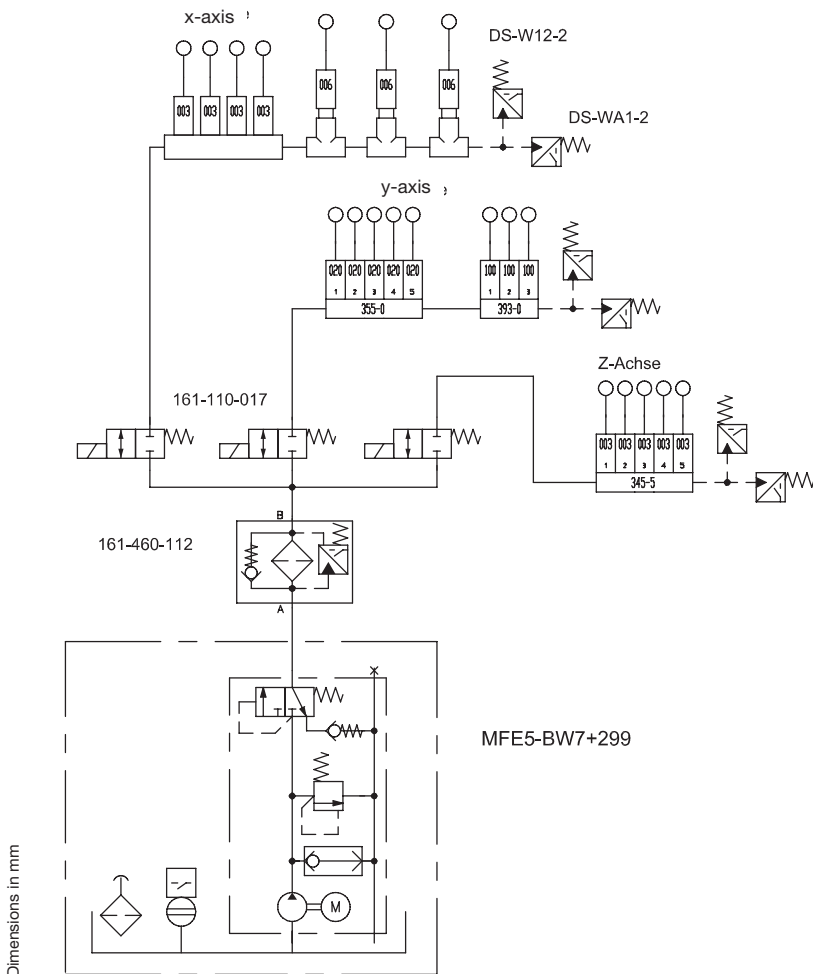

A 2/2-way valve is installed upstream of each respective distributor group so that each axis is supplied with the required lubricant independent of each other.

When an enable signal for the triggering of a lube pulse is emitted in the control system, the pump starts delivering lubricant and the 2/2-way valve of the respective axis opens. The distributors deliver the prestored amount of lubricant to the friction point at the pressure of the pump.

When the rated switching pressure is reached at the maximum-pressure switch, the pump unit is switched off after a pump running time of ≥ 5 seconds. The main line is relieved of pressure down to the residual pressure determined by the residual-pressure valve. When a residual pressure of approximately 1 bar is reached, the minimum-pressure switch is actuated. The 2/2-way valve closes as a result of this signal. The lubricant inside the distributors of this group is shifted to the metering chambers and is ready for the new lube cycle. The procedure is repeated for each axis.

In the case of special system configurations, e.g. hoses in trailing-cable installations, it is possible for the relief time to be delayed. In this case it is advisable to use metering units belonging to assembly group 321-403-2. These metering units work at a residual pressure of 3 bars, which means much greater system dependability.

Piston distributors, Group 320 0.01 – 0.16 ccm (for oil)

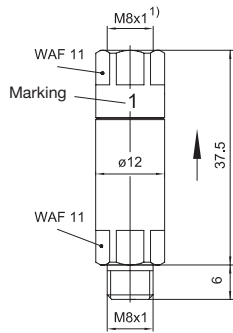

Metering units

Washer

Order No.	Rated metered quantity [ccm]	Marking on metering unit	Order No.
320-401-3	0.01	1	DIN7603-A8x11.5-CU
320-402-3	0.02	2	
320-403-3	0.03	3	
320-406-3	0.06	6	
320-410-3	0.10	10	
320-416-3	0.16	16	

The metering units can only be used together with distributor manifolds or tee pieces (cf. Brochure. 1-0103-US, "Fittings and auxiliary equipment").

For metering units for **direct** connection to lube points see pages 6 and 7.

1) Ports tapped for solderless tube connection.

Piston distributors, Group 340 0.01-0.16 ccm (for oil)

Please note: The piston distributors comprising Groups 340, 350 and 390 are only supplied complete with metering nipples. Possible tubing connection: M8x1 ports tapped for solderless ø4 tube connection.

See brochure 1-5015-US for piston distributors with quick connector system.

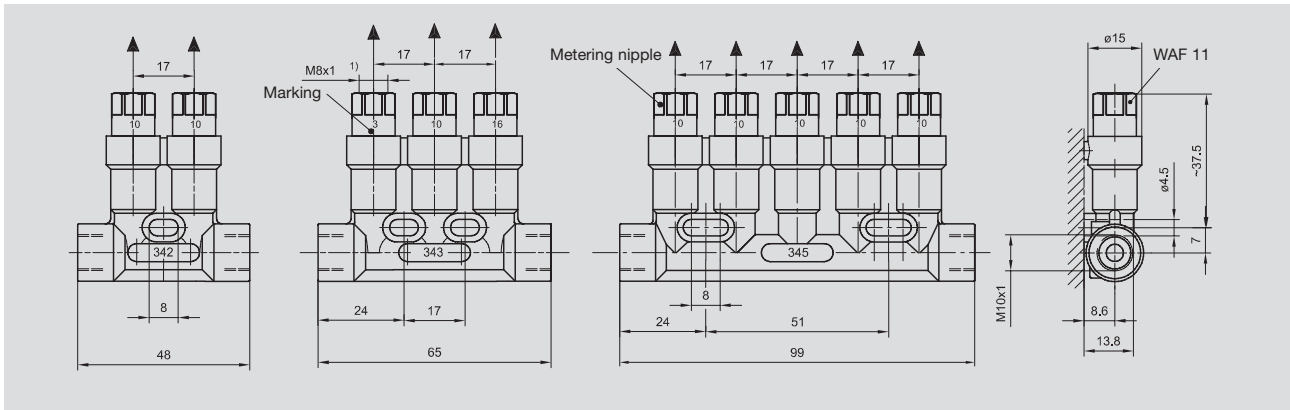

Piston distributors
(available only with metering nipples installed)

Order No.	Number of lube points
342-4...-000	2
343-4...-000	3
345-4...-...	5

Metering nipple with O-ring, exchangeable

Rated metered quantity [ccm]	Order key	Marking on the metering nipple	Order No.
0.01	1	1	Metering nipple not exchangeable
0.02	6	2	Metering nipple not exchangeable
0.03	2	3	995-994-103
0.06	3	6	995-994-106
0.10	4	10	995-994-110
0.16	5	16	995-994-116

To order: the order No. has 9 places
To complete the order No. supplement it with the **order key** in keeping with the desired metered quantities

Order example: piston distributor, 5-port type, 345-4...-...
metered with (from left to right) 0.03 – 0.10 – 0.10 – 0.16 – 0.06 ccm
Order key: 2 4 4 5 3
Order No.: 345-424-453

Group 340-... distributors are intended for **direct connection** to a main line with a diameter of 6 mm (double tapered ring and socket union).

1) Ports tapped for solderless tube connection.

Piston distributors, Group 350 0.1-0.6 ccm (for oil)

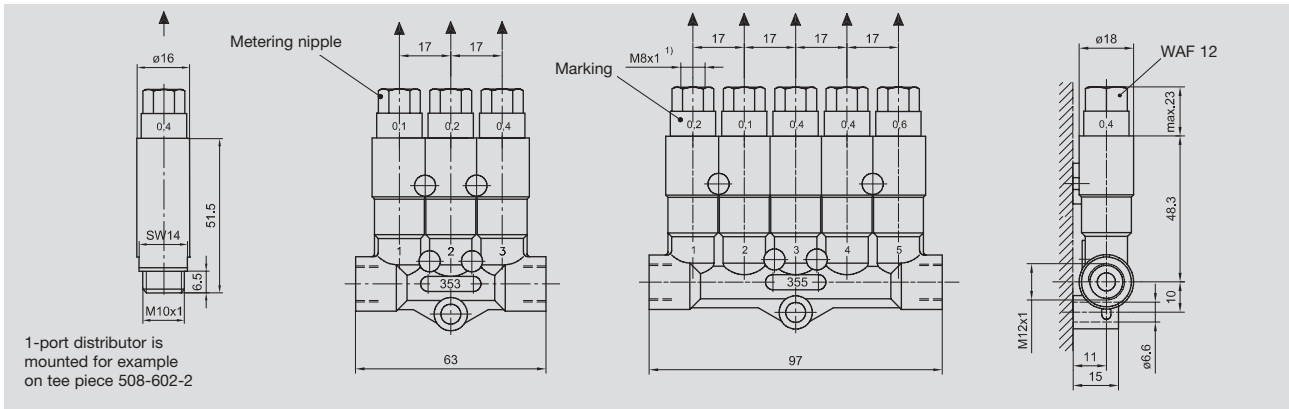

Piston distributors
(available only with metering nipples installed)

Order No.	Number of lube points
351-0.0-000	1
352-0..-000	2
353-0..-.00	3
355-0...-...	5

Metering nipple with O-ring, exchangeable

Rated metered quantity [ccm]	Order key	Marking on the metering nipple	Order No.
0.1	4	0.1	352-010-K
0.2	5	0.2	352-020-K
0.4	6	0.4	352-040-K
0.6	7	0.6	352-060-K

To order: the order No. has 9 places
To complete the order No. supplement it with the **order key** in keeping with the desired metered quantities.

Order example: piston distributor, 3-port type, 353-0..-.00
metered with (from left to right) 0.1 – 0.4 – 0.2 ccm
Order key: 4 6 5
Order No.: 353-046-500

Piston distributors, Group 390 0.2-1.5 ccm (for oil)

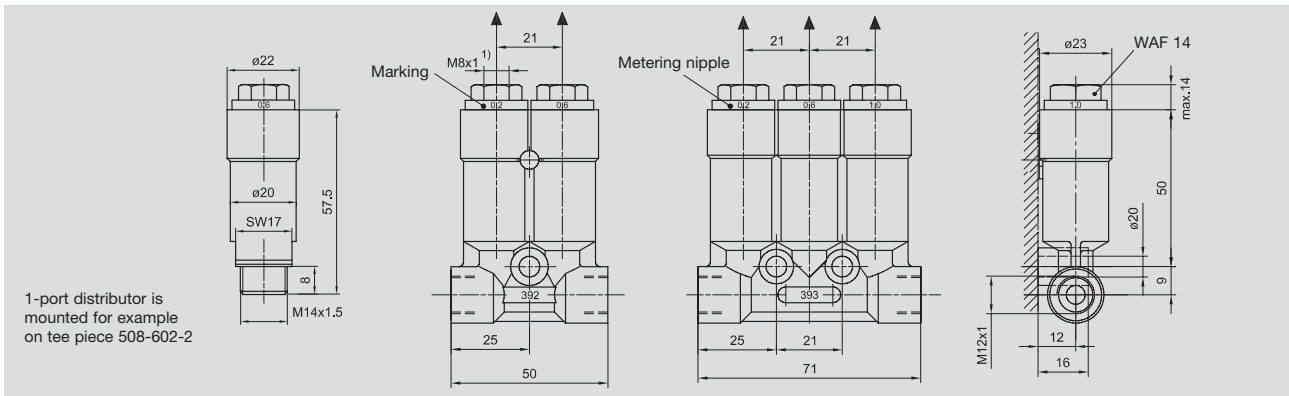

Piston distributors
(available only with metering nipples installed)

Order No.	Number of lube points
391-0.0-000	1
392-0..-000	2
393-0..-.00	3

Metering nipple with O-ring, exchangeable

Rated metered quantity [ccm]	Order key	Marking on the metering nipple	Order No.
0.2	5	0.2	391-020-K
0.4	6	0.4	391-040-K
0.6	7	0.6	391-060-K
1.0	8	1.0	391-100-K
1.5	9	1.5	391-150-K

To order: the order No. has 9 places
To complete the order No. supplement it with the **order key** in keeping with the desired metered quantities.

Order example: piston distributor, 3-port type, 393-0..-.00
metered with (from left to right) 1.5 – 1.0 – 0.4 ccm
Order key: 9 8 6
Order No.: 393-098-600

Dimensions in mm

1) Ports tapped for solderless tube connection.

Metering units for direct connection to lube points (for oil)

These metering units are used for direct connection to the lube point.

Pressure switches can be used in main lines (connection: pump – system distributors) to control the pressure build-up and – if necessary – the pressure reduction.

In the secondary lines (connection: distributors - lube point) the pump pressure no longer has a direct effect. Secondary lines have to be turned into main lines before they can be monitored. This is done by screwing metering units of **types G, L, T, W** directly into the lube point's threads.

The metering units are preassembled with union nuts or socket unions and (single) tapered rings, so installation of the tubing (plastic, steel and metal tubing) is simple:

- insert tube all the way to the stop (types **G** and **W** about 12 mm; types **L** and **T** about 20 mm).
- Tighten union nut or socket union.

To achieve the same advantage of simplified tubing connections on a distributor manifold as well, it is advisable, for example, to use tapered ring 404-611 for $\varnothing 4$ tubing and socket union 404-612 instead of the double tapered ring connection.

All four types are supplied complete with tapered ring and socket union (union nut).

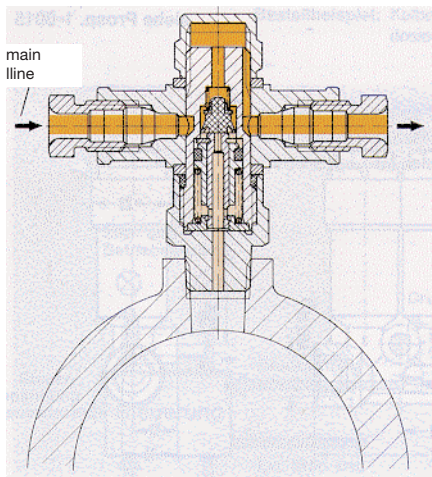

Type

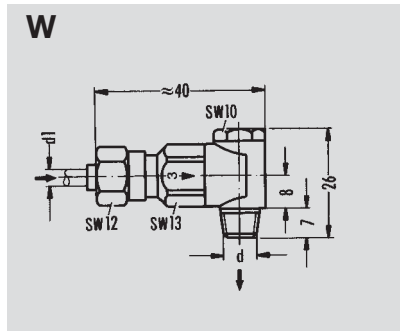
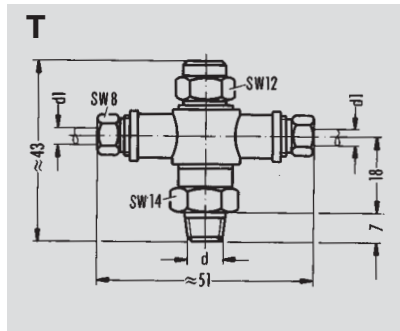
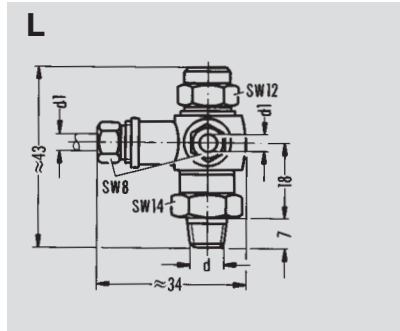
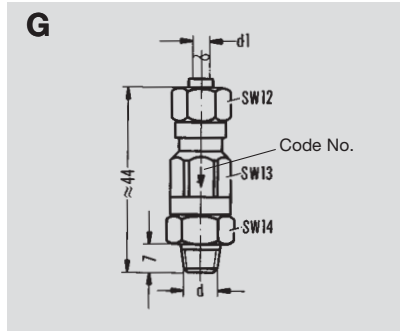

Metered quantity [cm ³]	Code number	Screwed stud end d	Order No.						
			Type G		Type L 1)	Type T		Type W	
			d1 = $\varnothing 4$	d1 = $\varnothing 6$	d1 = $\varnothing 4$	d1 = $\varnothing 4$	d1 = $\varnothing 6$	d1 = $\varnothing 4$	d1 = $\varnothing 6$
0.03	3	M 8x1 tap.	321-403G1	321-603G1	321-403L1	321-403T1		321-403W1	321-603W1
		M 10x1 tap.	321-403G2	321-603G2	321-403L2	321-403T2		321-403W2	321-603W2
		R 1/8 tap.	321-403G3	321-603G3	321-403L3	321-403T3		321-403W3	321-603W3
0.06	6	M 8x1 tap.	321-406G1	321-606G1	321-406L1	321-406T1		321-406W1	321-606W1
		M 10x1 tap.	321-406G2	321-606G2	321-406L2	321-406T2		321-406W2	321-606W2
		R 1/8 tap.	321-406G3	321-606G3	321-406L3	321-406T3	321-606T3	321-406W3	321-606W3
0.10	10	M 8x1 tap.	321-410G1	321-610G1	321-410L1	321-410T1		321-410W1	321-610W1
		M 10x1 tap.	321-410G2	321-610G2	321-410L2	321-410T2		321-410W2	321-610W2
		R 1/8 tap.	321-410G3	321-610G3	321-410L3	321-410T3	321-610T3	321-410W3	321-610W3

1) Type **L** not available for d1 = $\varnothing 6$

Metering units for direct connection to lube points (for oil)

Type G4

Metering units **to be directly screwed** into machine beds, supports, etc.

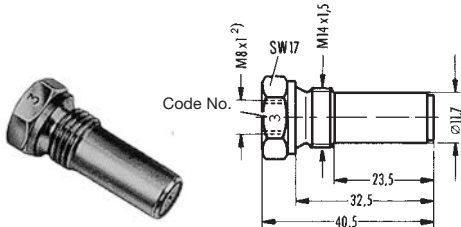

Metered quantity [ccm]	Code No.	Order No.
0.03	3	321-403G4
0.06	6	321-406G4
0.10	10	321-410G4

2) Ports tapped for solderless ø4 tube connection (main line connection).

Metering units **as module** to be screwed onto components

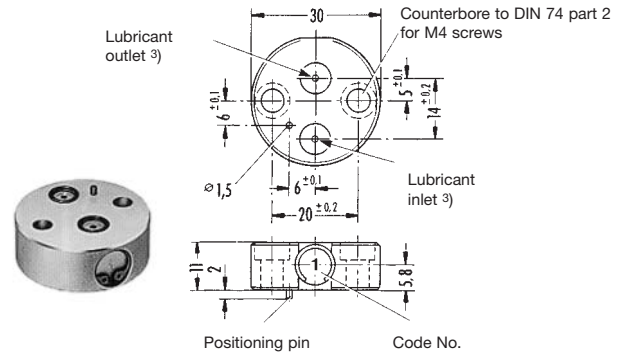

Metered quantity [ccm]	Code No.	Order No.
0.01	1	320-101
0.03	3	320-103
0.06	6	320-106

3) with counterbore for ø5x1 O-rings. O-rings are supplied detached

Type G7

Metering cartridges for **insertion**

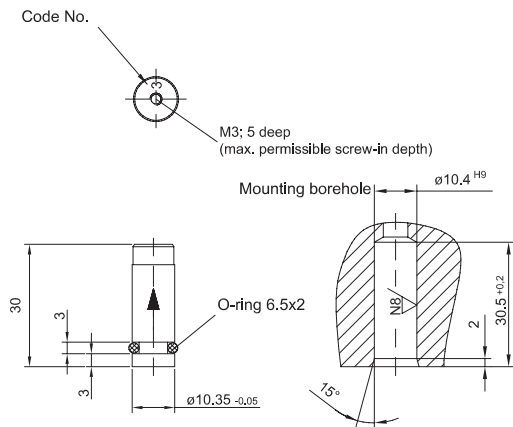

Metered quantity [ccm]	Code No.	Seal material	Order No.
0.03	3	NBR	321-403G7
0.06	6	NBR	321-406G7
0.10	10	NBR	321-410G7
0.03	3	FKM (FPM)	321-403G7-S8
0.06	6	FKM (FPM)	321-406G7-S8
0.10	10	FKM (FPM)	321-410G7-S8

Metering cartridges for **insertion**

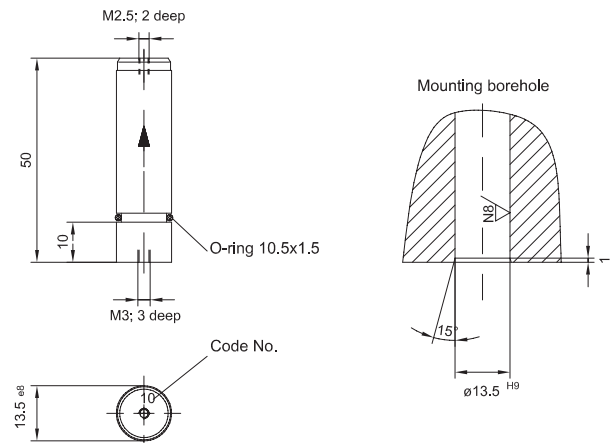

Metered quantity [ccm]	Code No.	Seal material	Order No.
0.10	10	NBR	351-410G7
0.16	16	NBR	351-416G7
0.20	20	NBR	351-420G7
0.30	30	NBR	351-430G7

Operating pressure: p min. 12 bars
p max. 45 bars
perm. residual pressure 3 bars

Operating pressure: p min. 12 bars
p max. 45 bars
perm. residual pressure 3 bars

Example of Group 350 Distributors:

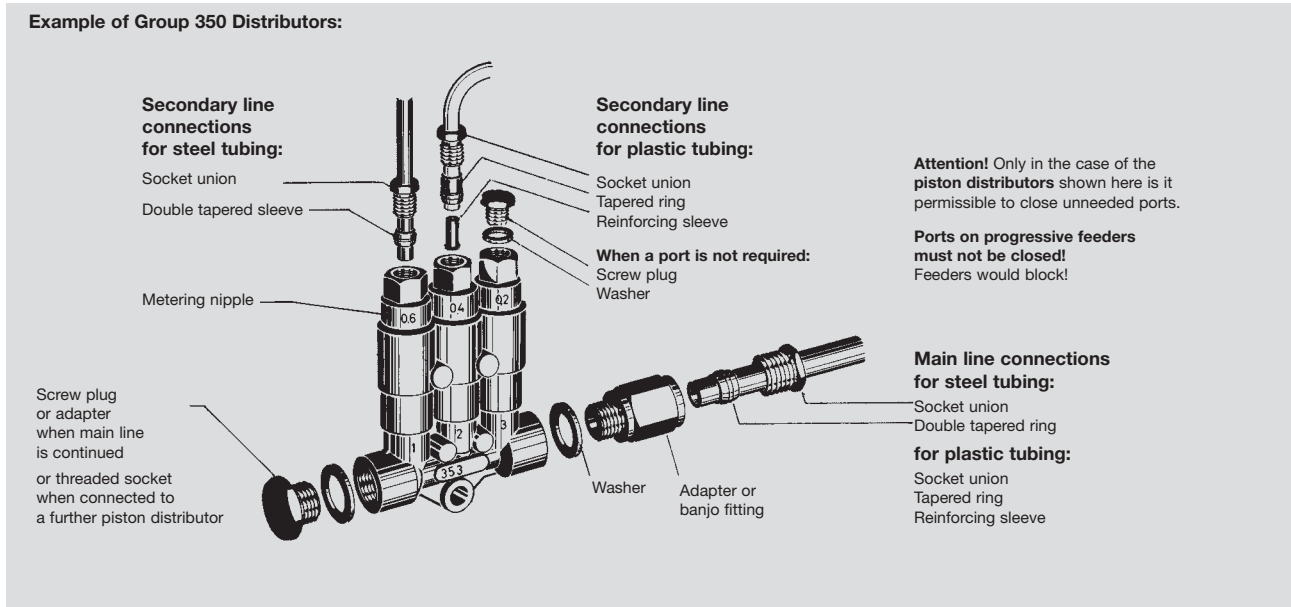

Leaflet information!

- 1-5015-US: Piston distributors with quick connector system
- 1-0103-US: Fittings and auxiliary equipment
- 1-0103-1-US: Quick connectors
- 1-1101-US: Piston pumps, manually operated
- 1-1108-US: Piston pumps, mechanically operated
- 1-1110-US: Piston pumps, hydraulically and pneumatically operated
- 1-1202-US: Gear pump units
- 1-1203-US: Compact units
- 1-1700-4-US: Control and monitoring units
- 1-1701-US: Pressure switches

Notice!

All products from VOGEL may be used only for their intended purpose. If operating instructions are supplied together with the products, the provisions and information therein of specific relevance to the equipment must be observed as well.

In particular, we call your attention to the fact that hazardous materials of any kind, especially the materials classified as hazardous by EC Directive 67/548/EEC, Article 2, Par. 2, may only be filled into VOGEL centralized lubrication systems and components and delivered and/or distributed with the same after consultation with and written approval from VOGEL.

All products manufactured by VOGEL are not approved for use in conjunction with gases, liquefied gases, pressurized gases in solution and fluids with a vapor pressure exceeding normal atmospheric pressure (1013 mbars) by more than 0.5 bar at their maximum permissible temperature.



A brand of the SKF Group

Willy Vogel AG
 Motzener Strasse 35/37
 12277 Berlin, Germany
 P.O. Box 970444 · 12704 Berlin
 Tel. +49 (0) 30 - 720 02-0
 Fax +49 (0) 30 - 720 02-111
 info@vogel-berlin.de
 www.vogelag.com

Willy Vogel AG
 2. Industriestrasse 4
 68766 Hockenheim
 Germany
 Tel. +49 (0) 62 05 - 27-0
 Fax +49 (0) 62 05 - 27-132
 info@vogel-berlin.de
 www.vogelag.com

Vogel France SAS
 Rue Robert Amy, B.P. 70130
 49404 Saumur cedex
 France
 Tel. +33 (0) 241 404 200
 Fax +33 (0) 241 404 242
 info@vogelfrance.com
 www.vogelfrance.com